



Ultrasonic welder and Vacuum picker

011170

011170 Highlights

- 35kHz Ultrasonic welding converter from Herrmann Ultraschall, available with Collobro sonotrodes, designed for your need. To be used with Collobro´s base integrated Herrmann us generator 1000 M CV
- Adjustable and pneumatically valve controlled air cooling of sonotrode for frequent welding.
- Collobro Instant Tool Changer ITC-W10P4E8-T (Payload 10kg, Pneumatic x4, Electric x8, Tool side)
- Flow efficient vacuum ejector with patented cartridge technology. Vacuum flow of 0,01 NI/s at 0,6MPa feed pressure and 70 -kPa vacuum level.
- 2 Double bellow DURAFLEX vacuum cups, equipped with Collobro anvil bowl design for a unique combination of secure vacuum grip on most surfaces and a firm, nonflexing hold of the product.
- 30 -kPa vacuum switch for picking confirmation.
- Omron photo electric, Diffuse-reflective, distance reader. Increases cobot speed, efficiency and flexibility in your application by for example enabling detection of picking/placing pattern and/or level, detecting products, machine tending status or obstacles.

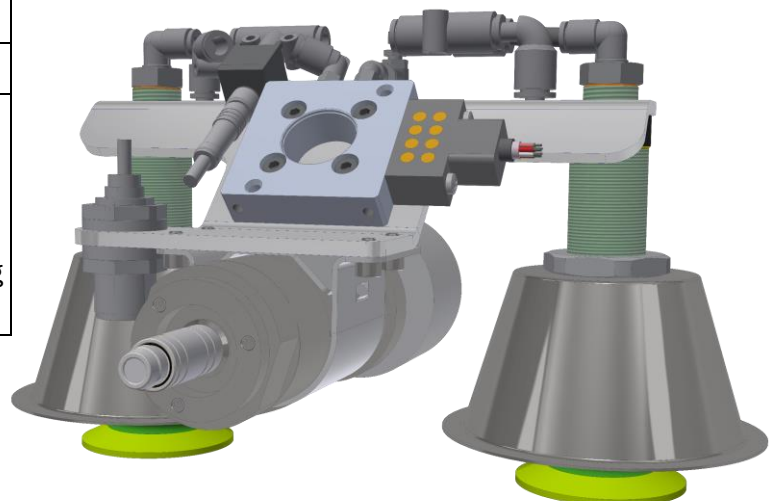

"Collobro provides the market with the most flexible and profitable solutions for collaborative robot applications."